

Deliverable D5.3: Documentation on ACTRIS National Facility labelling principles

Authors: Ulla Wandinger, Carmela Cornacchia, Jean-Francois Doussin, Markus Hermann, Hartmut Herrmann, Pirjo Kontkanen, Paolo Laj, Doina Nicolae, Gelsomina Pappalardo, Sabine Philippin, Christian Plaß-Dülmer, Sanna Sorvari

Work package no.	WP5
Deliverable no.	D5.3
Lead beneficiary	TROPOS
Deliverable type	<input checked="" type="checkbox"/> R (Document, report) <input type="checkbox"/> DEC (Websites, patent filings, videos, etc.) <input type="checkbox"/> OTHER: please specify
Dissemination level	<input checked="" type="checkbox"/> PU (public) <input type="checkbox"/> CO (confidential, only for members of the Consortium, incl. Commission)
Estimated delivery date	30/6/2019 (Month 30)
Actual delivery date	1/11/2018
Version	Final
Reviewed by	ACTRIS Community
Accepted by	Sanna Sorvari
Comments	The principles presented in this document have also been approved by Interim ACTRIS Council on 25.10.2018.

Contents

1	Purpose of the ACTRIS labelling process	2
2	ACTRIS labelling principles	3
3	Contents of the ACTRIS label.....	3
4	Framework of the ACTRIS labelling process.....	4
5	Steps and actions of the ACTRIS labelling process	5
5.1	Overview	5
5.2	Step 1a: Initial acceptance	5
5.3	Step 1b: Performance evaluation	7
5.4	Step 1c: Approval and granting of the ACTRIS label.....	7
5.5	Step 2: Regular re-evaluation.....	8
	Annex A: Applicable ACTRIS-PPP Documents.....	9

1 Purpose of the ACTRIS labelling process

ACTRIS National Facilities (NFs) consist of Observational and Exploratory Platforms, which are developed, managed, and operated by national **Research-Performing Organizations (RPOs)**. **Observational Platforms** are fixed ground-based stations that deliver long-term data based on a regular measurement schedule and common operation standards. **Exploratory Platforms** are atmospheric simulation chambers, laboratory platforms and mobile platforms that perform dedicated experiments and contribute data on atmospheric compounds, processes, events or regions by following common ACTRIS standards. The acquisition and delivery of quality-controlled data is the major task of the NFs. In addition, physical access for users to selected platforms is provided.

While decisions on the implementation and operation of NFs and respective funding solely fall to the member states, the tasks of the **ACTRIS ERIC** are to verify the compliance of proposed NFs with the ACTRIS technical concepts and requirements before the NFs enter the research infrastructure (RI) and to control the perpetuation of the ACTRIS standards at the NFs during the lifetime of the RI. Furthermore, the ACTRIS ERIC is responsible for ensuring the provision of data collected at the NFs and the management of physical access to the NFs. The **ACTRIS Central Facilities (CFs)** are in charge of providing the respective support. Six **Topical Centres (TCs)** are established to assist the NFs in all aspects of standardization and quality assurance. The ACTRIS Data Centre (DC) is responsible for the provision of quality-controlled data to the users, and the **Service and Access Management Unit (SAMU)** within the **ACTRIS Head Office (HO)** manages the physical access to the NFs.

The **ACTRIS labelling process** aims at ensuring the operational capacity of ACTRIS by granting the label "**ACTRIS National Facility**" to Observational and Exploratory Platforms that comply with the ACTRIS standards. The labelling process comprises necessary interactions between the ACTRIS ERIC, the CFs and the national RPOs that implement and operate the NFs, in order to assess and permanently monitor the compliance of the NFs with the ACTRIS standards. These standards are defined in various applicable documents (see Annex A). In particular, the technical concepts and requirements for ACTRIS NFs, including conditions for access provision, are described in the documents D5.1 (*Documentation on technical concepts and requirements for ACTRIS Observational Platforms*) and D5.2 (*Documentation on technical concepts and requirements for ACTRIS Exploratory Platforms*). Further principles regarding access and data policy are described in the documents D6.3 (*Report on access rules and modalities and recommendations for ACTRIS access policy*), D2.6 (*ACTRIS Access and Service Policy*) and D2.3 (*ACTRIS Data Policy*).

In this document, an overview of the ACTRIS labelling process is provided. Chapter 2 outlines the labelling principles. Chapter 3 specifies the contents of the ACTRIS label. In Chapter 4 an explanation is given on how the labelling process is embedded in the ACTRIS governance structure. Afterwards, Chapter 5 outlines the labelling process and describes the steps from the initial application of the NF to the granting of the label by the ERIC and the regular re-evaluation procedure. Further details, including templates of the application forms for ACTRIS Observational and Exploratory Platforms and the corresponding actions, will be detailed in a future document (new deliverable D5.4). Applicable documents and the link to the ACTRIS glossary are provided in Annex A.

2 ACTRIS labelling principles

The ACTRIS label is granted if all of the following conditions are fulfilled:

1. The member country or the responsible RPO(s) has (have) signed a commitment of the resources for long-term operation of the NF (RI operations are envisaged to run over >20 years, a commitment at least for the next 5 years is expected).
2. All contractual agreements required by the ERIC for NFs are signed by all parties.
3. The NF has demonstrated, according to the assessment report (see Chapter 5), to comply with the ACTRIS NF general principles (see D5.1, Chapter 3 and D5.2, Chapter 3).
4. The NF has demonstrated, according to the assessment report (see Chapter 5), to comply with the ACTRIS technical concepts and requirements for at least one type of ACTRIS platforms (see D5.1, Chapter 4 and D5.2, Chapter 4).
5. The NF has contributed to all required QA/QC measures and submitted the required amount of high-quality data to the ACTRIS DC for at least two preceding years, according to the assessment report (see Chapter 5).

The ACTRIS label may be withdrawn if one of the above conditions is not achieved anymore. The decision on granting and withdrawal of the ACTRIS label is made by the General Assembly.

3 Contents of the ACTRIS label

The awarded ACTRIS label is:

“ACTRIS National Facility”.

The following specifications shall be assigned together with the ACTRIS label:

“ACTRIS Observational Platform” or “ACTRIS Exploratory Platform”.

The ACTRIS label shall be accompanied with at least one *Certificate of Compliance* regarding

- Aerosol remote sensing
- Aerosol *in situ* measurements
- Cloud remote sensing
- Cloud *in situ* measurements
- Reactive trace gases remote sensing
- Reactive trace gases *in situ* measurements

for ACTRIS Observational Platforms or

- Mobile Platform
- Atmospheric Simulation Chamber
- Laboratory Platform

for ACTRIS Exploratory Platforms.

ACTRIS ERIC shall provide a visual display of the ACTRIS label.

4 Framework of the ACTRIS labelling process

Figure 1 shows the ACTRIS ERIC governance framework, in which the labelling process is embedded. The General Assembly (GA), consisting of the representatives of the member countries, is the decision-making body of ACTRIS and decides on the granting and withdrawal of the ACTRIS label. The Director General (DG) of the ACTRIS ERIC executes and administers the labelling process. The Research Infrastructure Committee (RI Com), consisting of representatives of the CFs (appointed by the directors and the management boards of the CFs) and representatives of the NFs (appointed by the National Facilities Assembly, NFA), is responsible for the overall scientific and technical evaluation of the NFs, based on the work and reporting performed by the CFs and the NFs during the labelling process (see Chapter 5 and D5.4 for details).

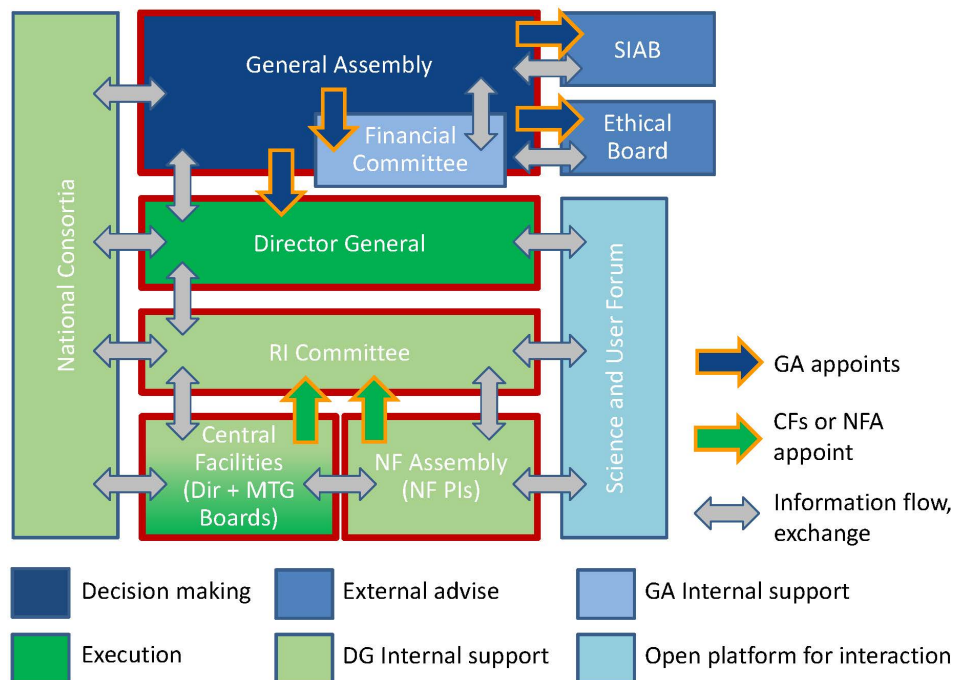

Fig. 1: ACTRIS ERIC governance framework. Red frames indicate the bodies directly involved in the ACTRIS labelling process.

5 Steps and actions of the ACTRIS labelling process

5.1 Overview

Figure 2 shows an overview of the ACTRIS labelling process in terms of a timeline connected to the ACTRIS National Facility lifecycle. The process consists of two major steps. The first step aims at granting the ACTRIS label for the first time and is conducted during the implementation and pre-operation phases of the candidate NF (which are not necessarily simultaneous to the respective phases of the ACTRIS ERIC). It comprises three sub-steps: 1a) initial acceptance, 1b) performance evaluation and 1c) approval. Step 2 of the labelling process represents the continuous monitoring and re-evaluation of the operational NF over the lifetime of the RI. The steps are outlined in detail in the next sections.

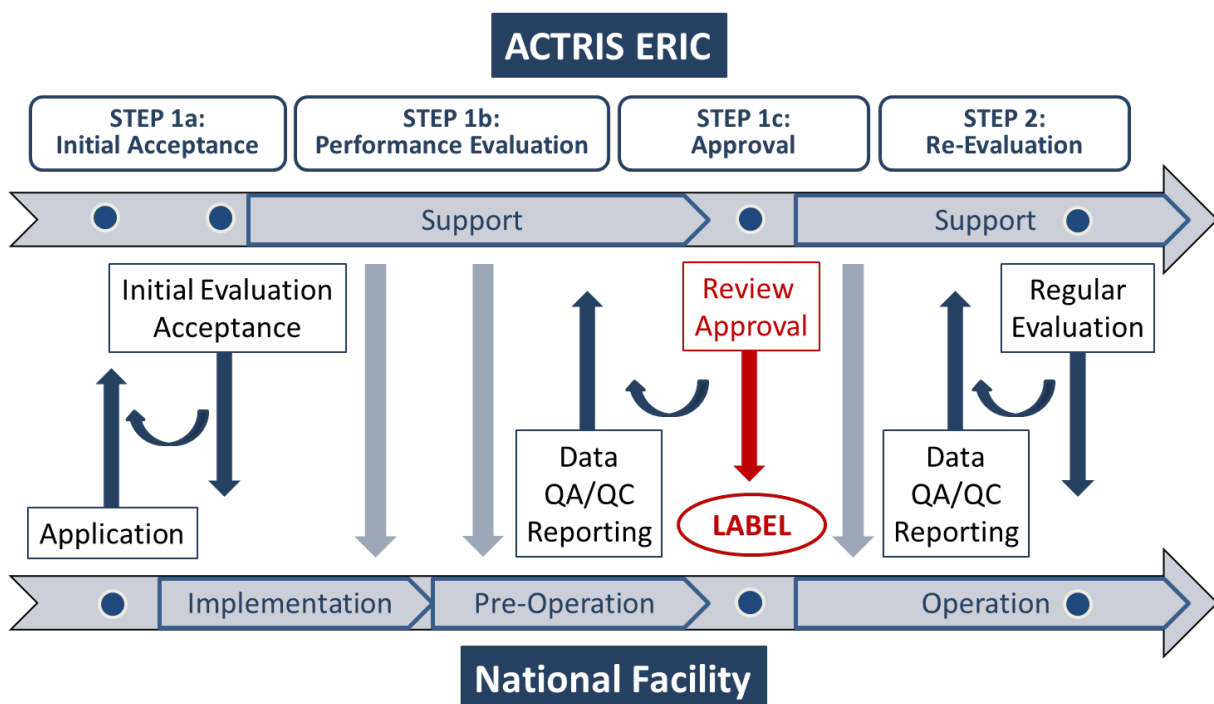

Fig. 2: Steps and actions of the ACTRIS labelling process. The upper horizontal arrow indicates the responsibilities of the ACTRIS ERIC, including the CFs, the RI Com and the GA, whereas the lower arrow stands for the activities of the NF. Vertical arrows illustrate the interactions between the ERIC and the NF. The dark blue dots on the horizontal arrows mark the major points of action within the process.

5.2 Step 1a: Initial acceptance

Step 1a of the labelling process aims at the initial acceptance of the candidate NF. The following course of action shall apply:

1. The potential NF is identified and agreed upon at country level, which may include national agreements on responsibilities, funding, governance, commitments, etc.

2. The country representative in the GA submits the application for the NF to the HO. If the NF belongs to a list of agreed NFs provided by the country to the HO, the application can also be submitted by the RPO(s) responsible for the NF. The application shall include
 - a description of the NF regarding platform type(s), name, host country, host institution(s), location, scientific role, heritage and goals,
 - a statement regarding the *Certificate(s) of Compliance* requested for the NF,
 - a description of the instrumentation to be operated and the variables (for Operational Platforms) or experimental data (for Exploratory Platforms) to be submitted,
 - a description of the expertise of the RPO(s) responsible for the NF,
 - a statement regarding intended provision of physical access to the NF and, if access shall be provided, a description of access capabilities and ability of service provision, together with demonstrated user interest (e.g., by past transnational access records or quantitative impact studies),
 - a statement of acceptance of the ACTRIS data policy, ACTRIS access and service policy and other relevant ACTRIS documents (as requested by the ERIC),
 - an indication of the operation support needed from the associated TC and DC units,
 - a 5-year plan describing the activities for implementation and (pre-)operation of the NF,
 - a commitment of the resources for long-term operation of the NF (RI operations are envisaged to run over >20 years, a commitment at least for the next 5 years is expected).

The ACTRIS ERIC shall provide the respective application forms for Observational and Exploratory Platforms. A layout will be provided in D5.4. If RPOs that intend to implement and operate an NF need advice for the application regarding, e.g., technical concepts, they may informally contact the associated CF units.

3. The HO initiates the evaluation process.
4. The application is evaluated by the RI Com, with support from the associated CF units. If necessary, clarifications may be requested from the RPO(s) that intend(s) to implement and operate the NF.
5. The RI Com makes a recommendation regarding the initial acceptance (or refusal) of the NF.
6. The Director General, with the mandate from the GA, makes the decision on the initial acceptance (or refusal) of the NF and informs the member country formally (Letter of Initial Acceptance/Refusal). In case of refusal, the letter must contain a detailed statement of the reasons and a follow-up recommendation (i.e., under which conditions a revised application is feasible).
7. If the NF is initially accepted, the representative of the NF receives the voting right in the National Facilities Assembly.

5.3 Step 1b: Performance evaluation

Step 1b of the labelling process comprises the performance evaluation during the NF implementation and pre-operation phases.

1. At the national level, work ensuring the proper installation of the NF following the ACTRIS standards is performed:
 - The NF is set up or upgraded according to the ACTRIS technical concepts and requirements.
 - The NF implements the ACTRIS standard procedures.
 - The NF participates in the required QA/QC activities.
 - The NF starts initial operation and submits data to the associated TC/DC units.
2. Continuous support is provided by the CFs:
 - The associated TC and DC units support implementation and pre-operation of the NF.
 - The associated TC units supervise the measurement QA/QC activities at the NF.
 - The associated TC and DC units supervise the data QA/QC activities at the NF and control the quality of data submitted by the NF.
 - The associated TC and DC units provide advice on improvements and adjustments, if necessary.
3. The HO coordinates exchange of information between CFs, RI Com and GA regarding the progress of implementation and pre-operation of the NF. Regular reporting may be requested. The HO initiates a common decision on the conclusion of the pre-operation phase when the candidate NF has demonstrated compliance with ACTRIS data submission and QA/QC requirements over a period of at least two preceding years (the period can start before the application was made, if the NF had already achieved the required level of compliance). If a candidate NF does not reach the required level of compliance in Step 1b after 5 years, the HO shall submit a report to the GA, and the GA may decide on the refusal of the candidate NF.

5.4 Step 1c: Approval and granting of the ACTRIS label

Step 1c of the labelling process aims at approval of the NF and granting of the ACTRIS label. The following course of action shall apply:

1. The HO initiates the readiness review by requesting the respective reports.
2. The NF reports on the status of readiness to the HO.
3. The associated TC and DC units report on the NF performance to the HO.
4. The RI Com evaluates the readiness status and provides the recommendation for approval of the NF.
5. The HO prepares the assessment report for the GA.
6. The GA makes the decision on the approval of the NF and the granting of the ACTRIS label.

7. The HO prepares the contractual agreements which must be signed by all parties.
8. The HO awards the ACTRIS label to the NF.

5.5 Step 2: Regular re-evaluation

Step 2 of the labelling process facilitates the continuous monitoring and regular performance assessment of the NF, which will be part of the overall research infrastructure operative monitoring and evaluation. Details of the NF re-evaluation procedure will be introduced in D5.4. The overall RI monitoring and evaluation concept will be defined during the ACTRIS implementation phase.

During the lifetime of the RI, the following obligations for maintaining the ACTRIS label shall apply:

1. A continuous monitoring of the NF performance is carried out by the associated TC and DC units, and by the SAMU for NFs providing physical access. The results are regularly reported to the HO. Severe issues of non-compliance of NFs with the ACTRIS requirements obtained during this monitoring process shall be reported to the GA, which may take further action.
2. A formal re-evaluation of the NF shall take place every 5 years and shall require the following actions:
 - The NF reports on its activities over the last 5 years, provides a new 5-year plan and a renewal of the commitment of the resources for long-term operation (at least for the next 5 years) to the HO.
 - The associated TC and DC units, and the SAMU for NFs providing physical access, provide an assessment of the performance of the NF to the HO (assessment criteria will be defined in D5.4).
 - The HO assesses the administrative and management performance of the NF (assessment criteria will be defined in D5.4).
 - The HO provides an assessment report to the GA.
 - The GA decides on the confirmation or withdrawal of the ACTRIS label.
 - The HO informs the member country formally.

In case of withdrawal of the ACTRIS label, the HO shall provide a detailed statement of the reasons and a follow-up recommendation, including the conditions under which a reapplication and restart of the labelling process are feasible.

Annex A: Applicable ACTRIS-PPP Documents

ACTRIS Glossary: <https://www.actris.eu/About/ACTRIS/ACTRISglossary.aspx>

D1.1: ACTRIS Governance and management structure

D2.3: ACTRIS Data Policy

D2.6: ACTRIS Access and Service Policy

D3.1: ACTRIS Cost Book

D4.1: Concept document on ACTRIS Central Facilities structure and services

D4.2: ACTRIS Data Management Plan

D5.1: Documentation on technical concepts and requirements for ACTRIS Observational Platforms

D5.2: Documentation on technical concepts and requirements for ACTRIS Exploratory Platforms

D6.3: Report on access rules and modalities and recommendations for ACTRIS access policy